

TOP VIEW

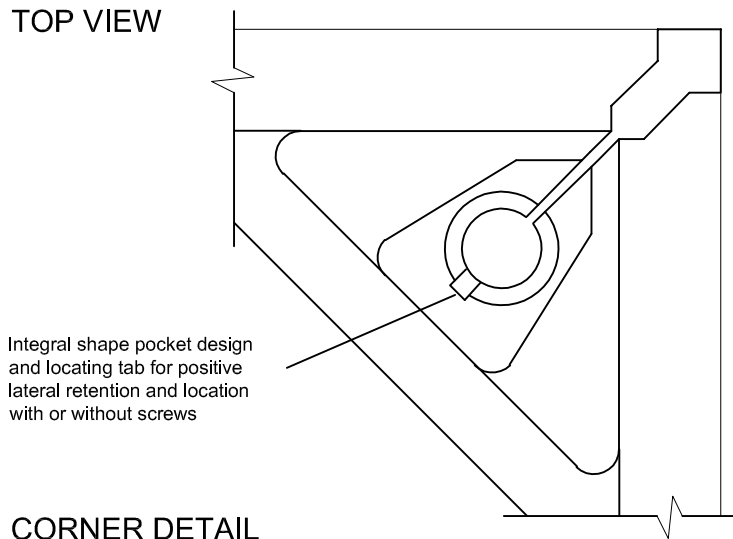

CORNER DETAIL



Tile w/ Top Set Trim

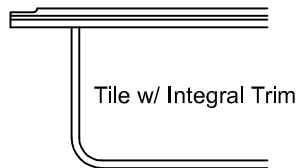

Tile w/ Integral Trim

## Performance Selection Chart

System Type	SYSTEM WEIGHT	STATIC LOADS				ROLLING LOADS		IMPACT LOADS
		Concentrated Loads	Top Surface Deflection	Uniform Loads	Ultimate Loads	10 Passes	10,000 Passes	
ConCore CC2500-24" Bolted Stringer	12.0 lbs / ft <sup>2</sup> 59 kg / m <sup>2</sup>	2500 lbs 1134 kg	0.100" 2.54 mm	625 lbs / ft <sup>2</sup> 29.8 kPa	6000 lbs	1500 lbs 680 kg	2000 lbs 907 kg	150 lbs 68 kg

Concentrated, ultimate, and impact load capacities are tested by imposing loads on a one square inch area. Results indicate weakest point of panel.

Permanent set after application of concentrated load shall be <0.010". Local and overall deformation after application of rolling loads shall be <0.040"

## SPECIFICATIONS

### General information

- Panel weight : 11.5 lbs./ft<sup>2</sup> bare.
- 1-3/8 inches deep with no covering.
- All steel welded construction filled internally with a cementitious core material.
- Protected from corrosion by an epoxy paint finish.
- Class A flame spread rating.
- Non-combustible material.

## UNDERSTRUCTURE OPTIONS

- 4" Heavy Duty Bolted Stringer w/ fillet welded heads
- Posilock

## COVERING OPTIONS

Tile factory laminated with top set trim edge

- 1/16" HPL \_\_\_\_\_ (Color) \_\_\_\_\_
- 1/16" Conductive HPL \_\_\_\_\_ (Color) \_\_\_\_\_
- 1/8" HPL \_\_\_\_\_ (Color) \_\_\_\_\_
- 1/8" Conductive HPL \_\_\_\_\_ (Color) \_\_\_\_\_

Tile factory laminated with integral trim edge

- 1/8" HPL \_\_\_\_\_ (Color) \_\_\_\_\_
- 1/16" HPL \_\_\_\_\_ (Color) \_\_\_\_\_
- 1/8" Conductive HPL \_\_\_\_\_ (Color) \_\_\_\_\_
- 1/16" Conductive HPL \_\_\_\_\_ (Color) \_\_\_\_\_

Bare Painted Panel Options

- Bare Finish to accept carpet tile application
- Bare Painted Finish to accept PosiTILE application